

NPA

New Product Announcement No. 2019-19



HUSHBORE

ANTI VIBRATION BAR

Vibration Free Boring Bar Line
with Exchangeable Heads

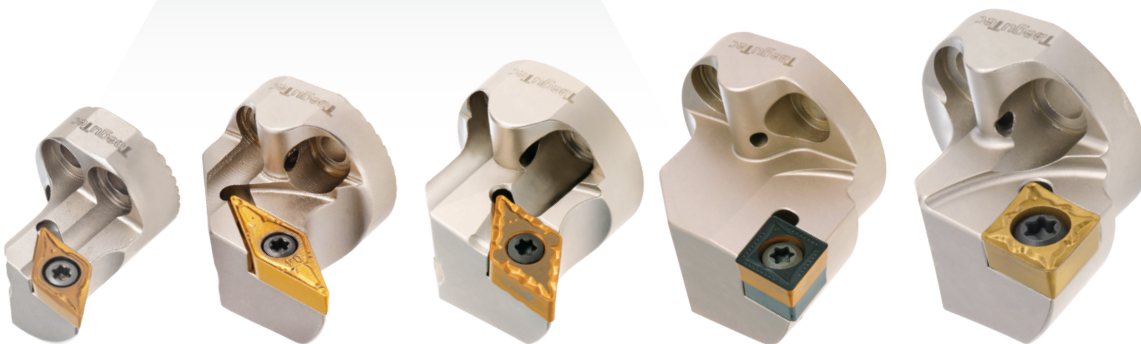
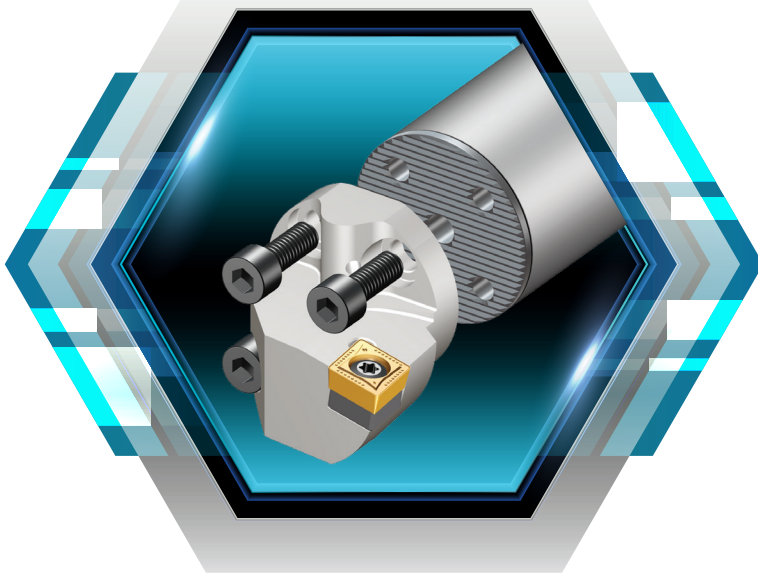

KEY POINT

TaeguTec has launched the HUSH-BORE line, a head exchangeable vibration free boring bar line for deep internal turning.

Machining depth in internal turning differs according to the shank materials of bars used; steel boring bars are used up to 3XBD (bar diameter) and carbide boring bars up to 5XBD. Deep internal turning, however, is very difficult to machine even with carbide boring bars. With the **HUSH-BORE's** damping system, TaeguTec has provided an internal turning solution up to 10XBD.

The **HUSH-BORE's** damping system located inside the shank is capable of deep internal machining more than 5XBD, this dramatic damping capability enables very good surface roughness of the workpiece and results in longer tool life and stable machining. It also means increased feed and cutting speed, making it more productive.

Shanks for the **HUSH-BORE** line are available as standard items in 7 different diameters (\varnothing 16, 20, 25, 32, 40, 50, 60 mm) and in 2 lengths (7XBD, 10XBD). The various exchangeable heads can be securely fastened with serrated couplings located in the boring bars.

Boring bar machining range (based on maximum depth of cut)

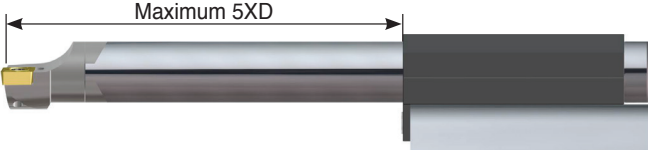
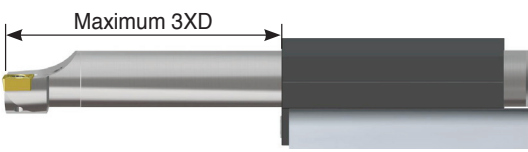
<p>HUSH-BORE</p>	 <p>Maximum 10XD</p>
<p>Carbide shank</p>	 <p>Maximum 5XD</p>
<p>Steel shank</p>	 <p>Maximum 3XD</p>

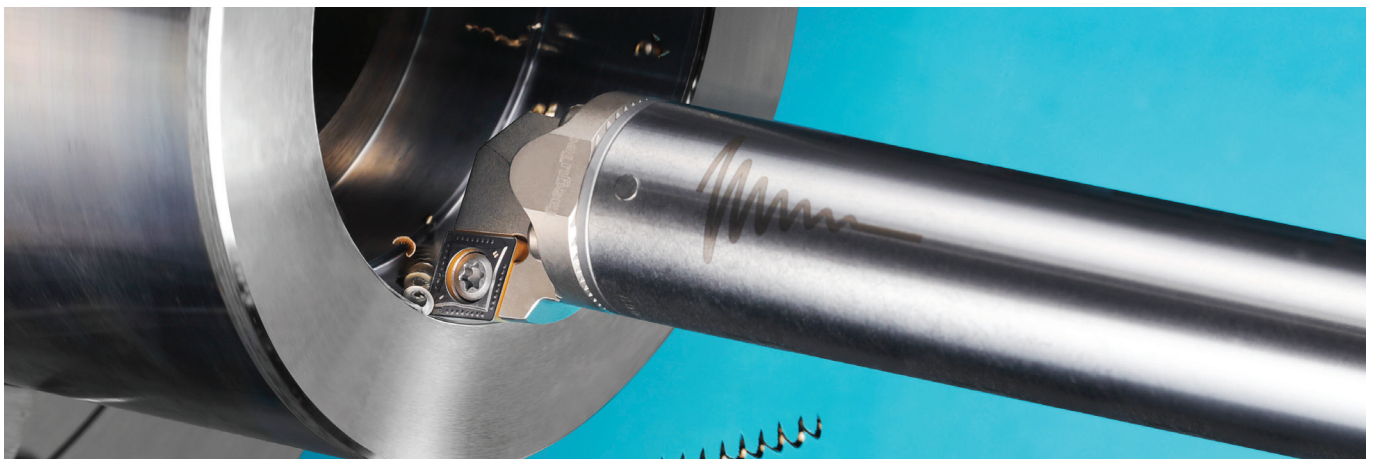

HUSH-BORE shank features

- Internal vibration damping system
 - Good surface finish and tool life
 - Higher depth of cut and feed enables better productivity
- Serrated coupling design for robust tightening
- Corrosion resistant stainless steel shanks
- Available as standard items in 2 different lengths: 7XBD, 10XBD
- Shanks available as standard items in 7 diameters
 - : Ø16, 20, 25, 32, 40, 50, 60 mm



serrated coupling capable

HUSH-BORE exchangeable head features

- A variety of head types with various specifications
- Available inserts
 - ISO positive inserts: CCMT, DCMT, VBMT
 - RHINO-TURN negative inserts: DNMG 13, DNMX 08, WNMX 04
 - RHINO-M-TURN negative inserts: CNMX 07, DNMX 08, WNMX 04
 - RHINO-X-TURN negative inserts: XNMG 09, 11
- Through coolant system directly on to the cutting edge for improved chip control and better tool life

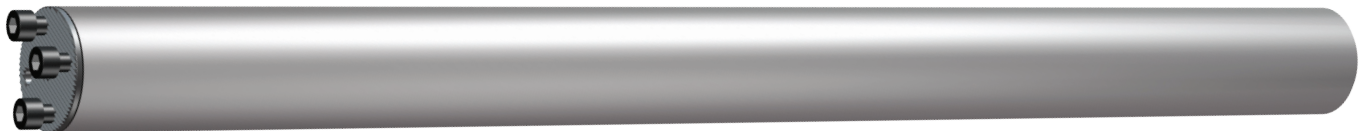

Standard shank designation system

QS □□□ - □

① ② ③ ④

- ① **HUSH-BORE** shank
- ② Shank diameters
Ø16, 20, 25, 32, 40, 50, 60 mm
- ③ Shank material and coolant hole
A: Internal supply type steel shank
E: Internal supply type carbide shank
- ④ Shank length 7XBD, 10XBD
ex: QS25A-10D

Standard head designation system

QH □□ - □□ - □

① ② ③ ④ ⑤

- ① **HUSH-BORE** head
- ② Shank connection sizes (DCONWS)
Ø16, 20, 25, 32, 40 mm
- ③ Special "X"
- ④ Head type (same as standard boring bars)
- ⑤ Options
ex: QH25-SCLCR 09
QH20X-SDUCR 07-F32

Select inserts that generate low cutting force to minimize vibration

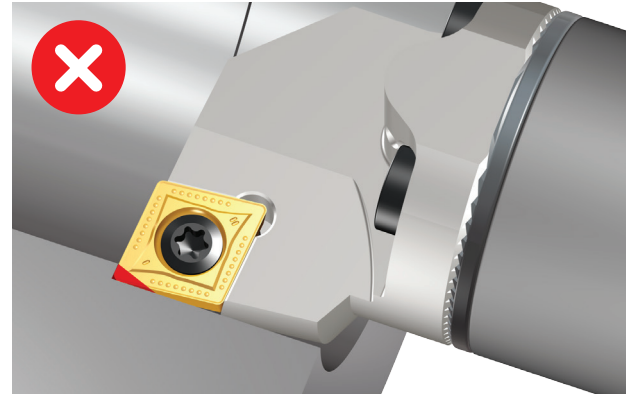
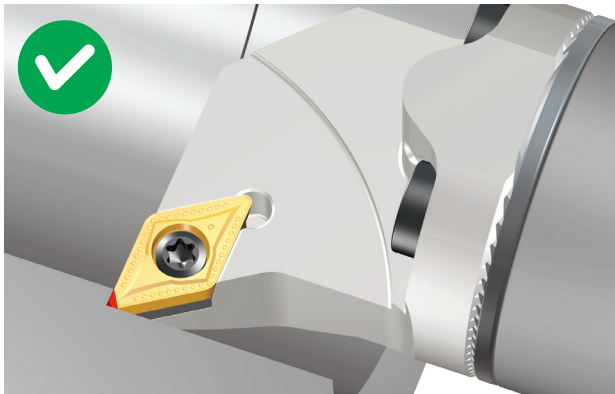

- D-Type provides more advantages than the C-Type with reduced rear contact area of the cutting edge.
- Stay as close to a 90 degrees entering angle as possible

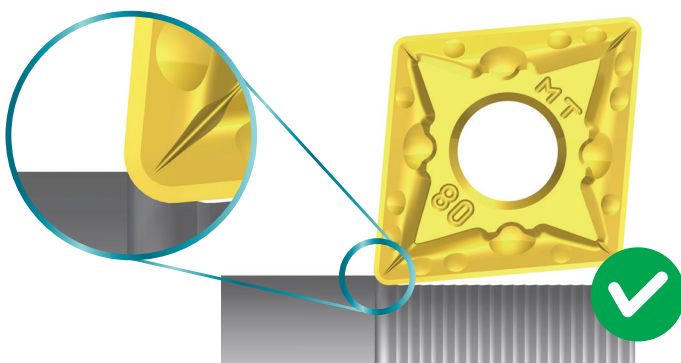

ISO Insert

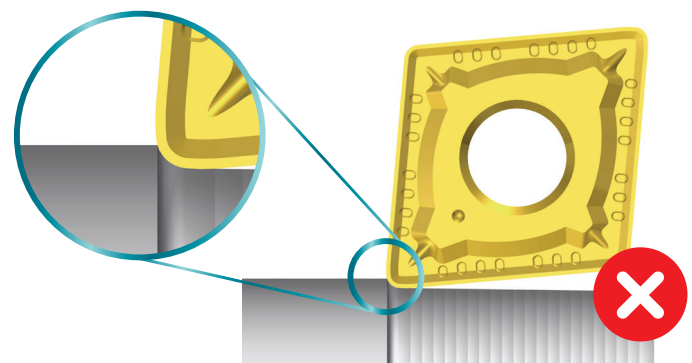

Wiper Insert

- Wiper inserts are highly prone to vibration during machining, so it is recommended to use a standard ISO type insert.
- TaeguTec recommends using inserts with small corner radii.
- Long chips can cause vibrations, so it is recommended to use inserts with good chip control.

Maximum shank cutting position



Since there is a damping system on the head side, it is possible to cut up to the display line when shank cutting.

Setting instructions

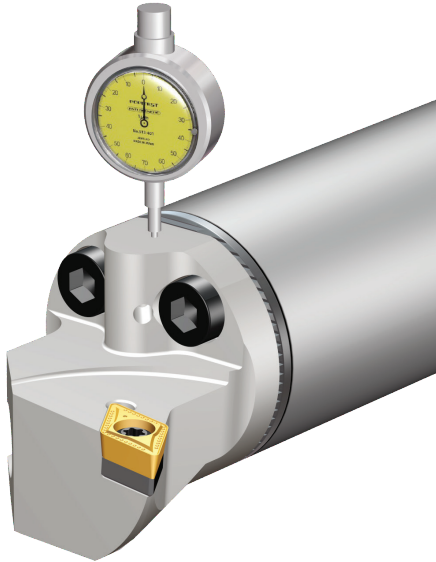

Set the shank to the holder so that the head's upper surface is horizontal to the gauge.

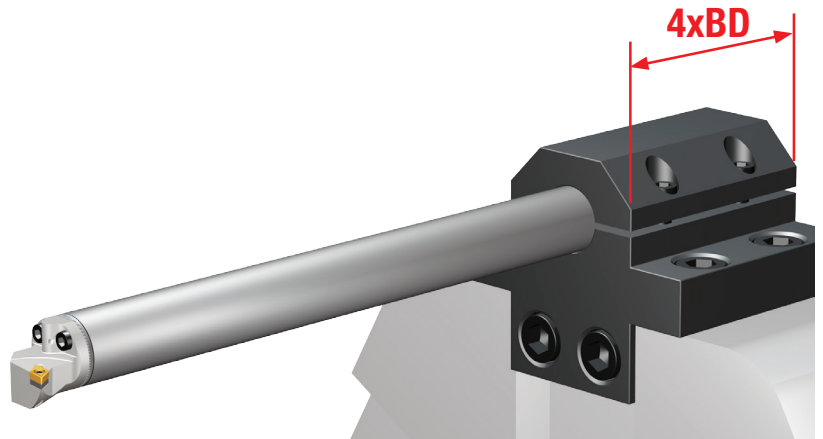

The mounted shank requires a length of at least 4XBD.

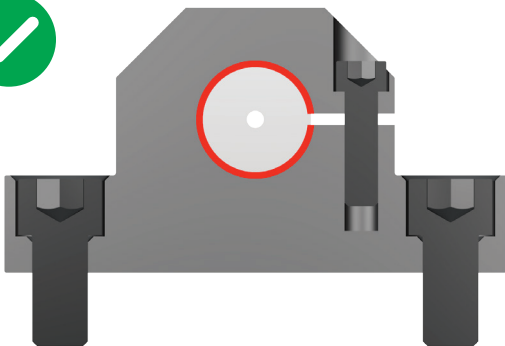

TaeguTec recommends the use of slit holders that have the full surface contact of the shank's cylinder.

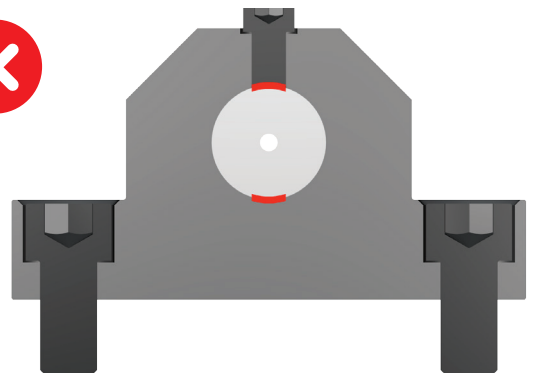

It is not recommended to use side lock clamping during operation; this will put the screw in direct contact with the shank.

Availability

In stock

Price

Available in the GAL system

Sincerely,
TaeguTec

Bae Dae-wi
Non-Rotating General PM

QS



Anti-vibration shanks for boring

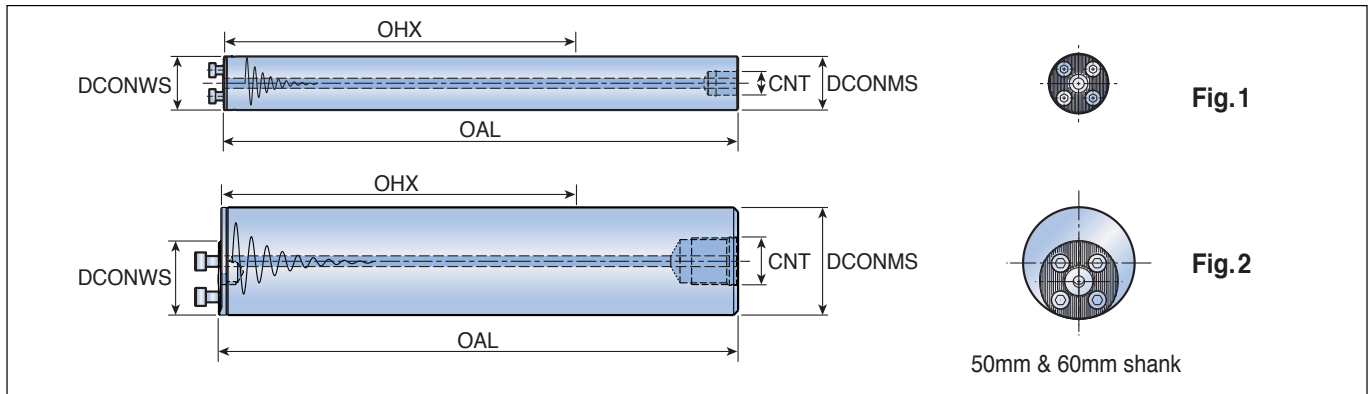

Designation	Dimension (mm)					Coolant	Fig.
	DCONMS	DCONWS	OAL	OHX	CNT		
QS16A-7D	16	16	156	92	G 1/8	●	1
QS16E-10D ⁽¹⁾	16	16	204	140	-	●	1
QS20A-7D	20	20	200	120	G 1/4	●	1
QS20E-10D ⁽¹⁾	20	20	260.3	180	-	●	1
QS25A-7D	25	25	257.5	155	G 1/4	●	1
QS25A-10D	25	25	330	230	G 1/4	●	1
QS32A-7D	32	32	323	192	G 3/8	●	1
QS32A-10D	32	32	416	288	G 3/8	●	1
QS40A-7D	40	40	408	248	G 1/2	●	1
QS40A-10D	40	40	528	368	G 1/2	●	1
QS50A-7D	50	40	518	318	G 1/2	●	2
QS50A-10D	50	40	668	468	G 1/2	●	2
QS60A-7D	60	40	628	388	G 3/4	●	2
QS60A-10D	60	40	813	568	G 3/4	●	2

- OHX: Maximum overhang
- ⁽¹⁾ Carbide shank

Spare parts

Designation	Screw	Wrench			
QS16	SH M3x0.5X10	L-W 2.5			
QS20	SH M3.5x0.6X10	L-W 2.5			
QS25	SH M4x0.7X12	L-W 3			
QS32	SH M5x0.8X12	L-W 4			
QS40/50/60	SH M6x1X16	L-W 5			



QH-HDUNR/L QH-HVUNR/L

Hook lever type boring heads

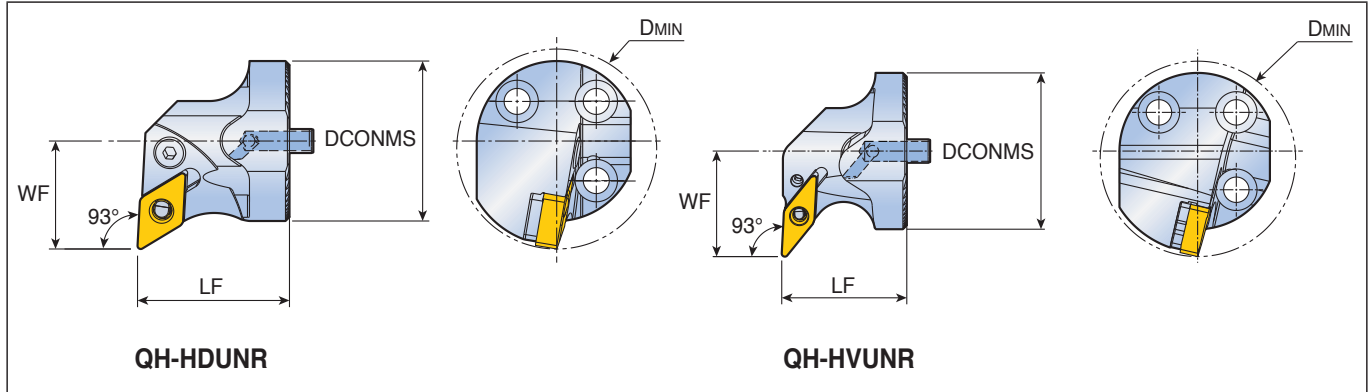

Approach angle	Designation	Dimension (mm)				Coolant	Insert
		DCONMS	LF	WF	DMIN		
93°	✓ QH40-HDUNR/L-1305	40	38	27	50	•	DN...G 1305...
93°	✓ QH40-HVUNR/L-1304	40	32	27	50	•	VN...X 1304...

• ✓ Marked: For RHINO-TURN insert

Spare parts

Designation	Lever	Lever screw	Shim		Shim pin	Wrench
HDUNR/L-1305	LCL 11-NX	LCS 4S	LSD 3.52B	-	LSP 4	L-W 3
HVUNR/L-1304	LCL 08-NX	LCS 4-DH	-	LSV 2.51.8H	LSP 3B	L-W 2.5

QH-SCLCR/L



Screw type boring heads

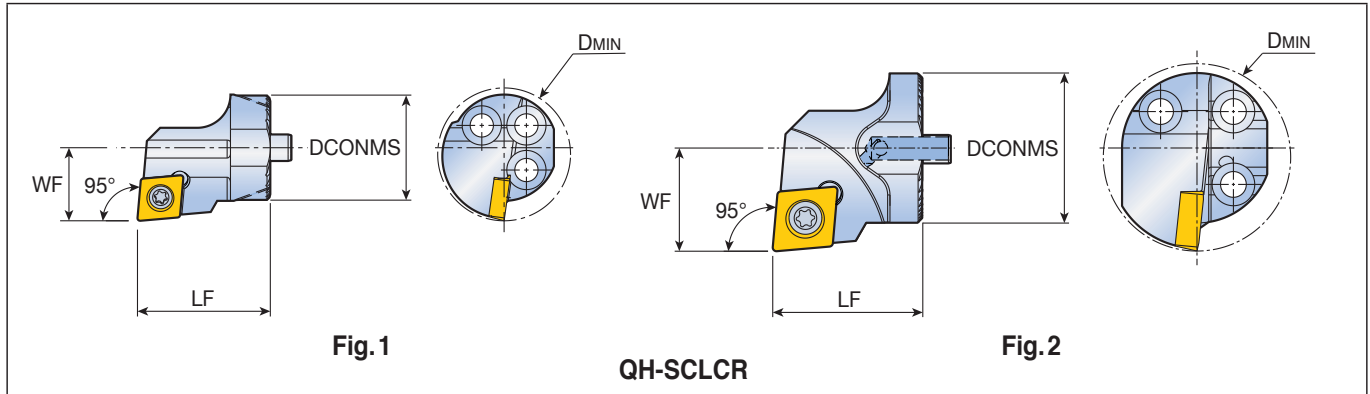

Approach angle	Designation	Dimension (mm)				Coolant	Fig.	Insert
		DCONMS	LF	WF	DMIN			
 95°	QH16-SCLCR/L-06	16	20	11	20	●	1	CC...T 0602...
	QH20-SCLCR/L-09	20	20	13	25	●	2	CC...T 09T3...
	QH25-SCLCR/L-09	25	22	17	32	●	2	
	QH32-SCLCR/L-12	32	32	22	40	●	2	CC...T 1204...
	QH40-SCLCR/L-12	40	38	27	50	●	2	

Spare parts

Designation	Screw	Shim	Shim screw	Wrench	
...06	SO 25065I	-	-	T 7	
...09	SO 35080I	-	-	T 15	
QH32...12	SO 45100I	-	-	T 20	
QH40...12	SO 45130I	SSC 43N	SO 60105S	T 20	

QH-SCLNR/L



Screw type boring heads

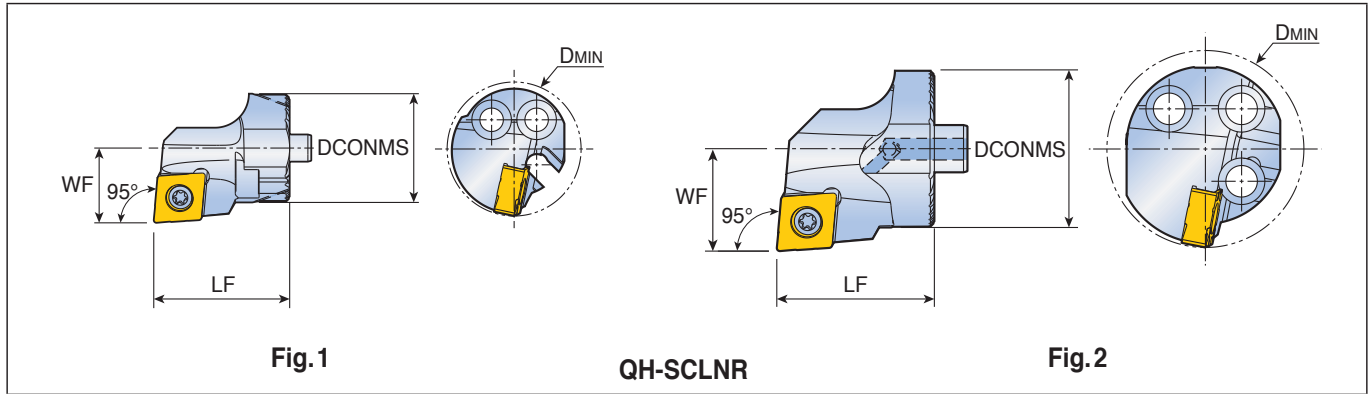

Approach angle	Designation	Dimension (mm)				Coolant	Fig.	Insert
		DCONMS	LF	WF	DMIN			
95°	* QH16-SCLNR/L-0703	16	20	11	20	•	1	CN...X 0703...
	* QH20-SCLNR/L-0703	20	20	13	25	•	2	

• *Marked: For RHINO-M-TURN insert

Spare parts

Designation	Screw	Wrench			
	...0703	TS 25D060/HG-P	T 7P		

QH-SDUCR/L



Screw type boring heads

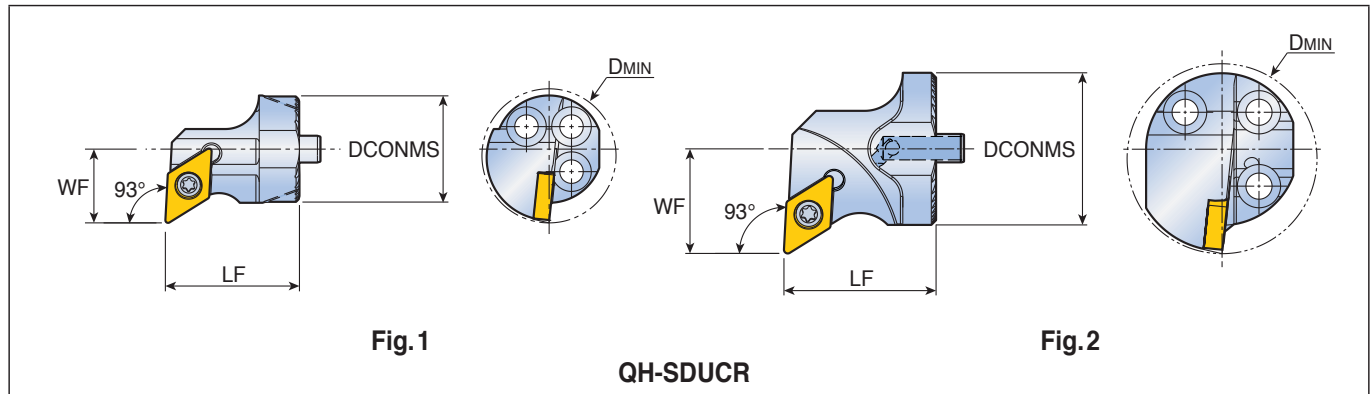

Approach angle	Designation	Dimension (mm)				Coolant	Fig.	Insert
		DCONMS	LF	WF	D _{MIN}			
<p>93°</p> <p>30° max.</p>	QH16-SDUCR/L-07	16	20	11	20	•	1	DC...T 0702...
	QH20-SDUCR/L-11	20	20	13	25	•	2	DC...T 11T3...
	QH25-SDUCR/L-11	25	22	17	32	•	2	
	QH32-SDUCR/L-11	32	32	22	40	•	2	
	QH40-SDUCR/L-11	40	38	27	50	•	2	

Spare parts

Designation	Screw	Shim	Shim screw	Wrench	
...07	SO 25065I	-	-	T 7	
...11	SO 35080I	-	-	T 15	
QH40...11	SO 35124I	SSD 32	SO 50090S	T 15	



QH-SDUNR/L

Screw type boring heads

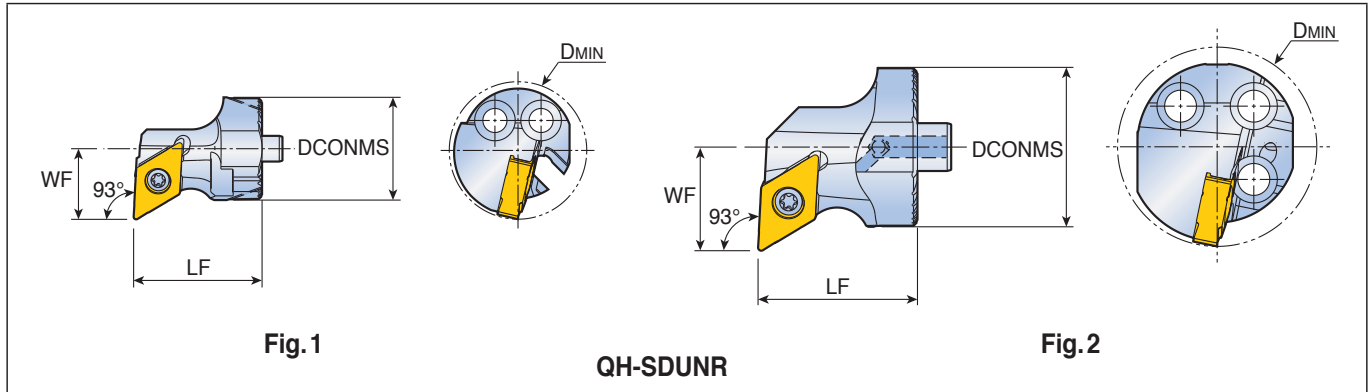

Approach angle	Designation	Dimension (mm)				Coolant	Fig.	Insert
		DCONMS	LF	WF	DMIN			
<p>30° max.</p>	* QH16-SDUNR/L-0803	16	20	11	20	●	1	DN...X 0803..
	* QH20-SDUNR/L-0803	20	20	13	25	●	2	
	✓ QH32-SDUNR/L-1305	32	32	22	40	●	2	DN...G 1305...

- * Marked: For RHINO-M-TURN insert
- ✓ Marked: For RHINO-TURN insert

Spare parts

Designation	Screw	Wrench			
...0803	TS 25D060/HG-P	T 7P			
...1305	TS 40G110I	T 15			

QH-SVUBR/L





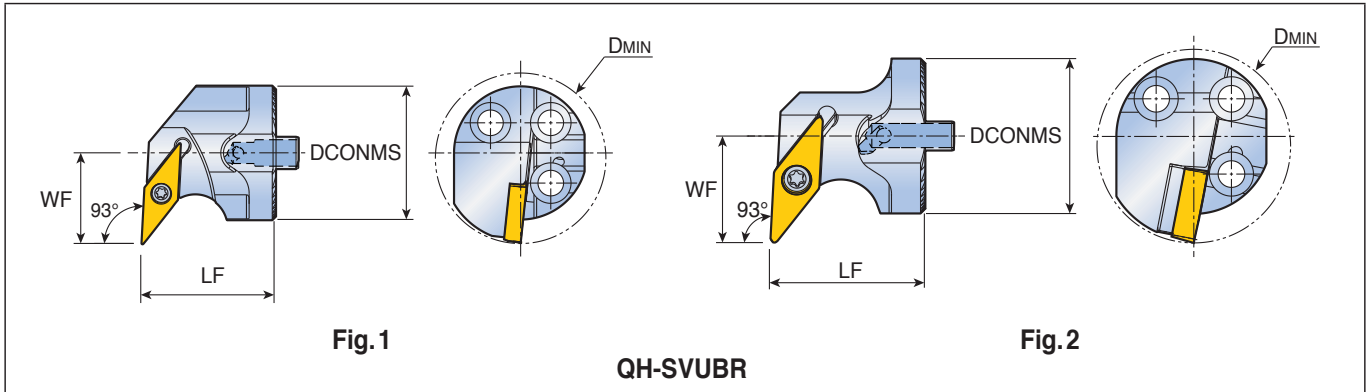

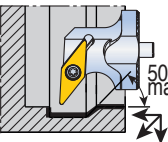
Screw type boring heads



Approach angle	Designation	Dimension (mm)				Coolant	Fig.	Insert
		DCONMS	LF	WF	DMIN			
93° 	QH20-SVUBR/L-11	20	20	16	27	•	1	VB...T 1103...
	QH25-SVUBR/L-11	25	25	17	31	•	1	
	QH32-SVUBR/L-16	32	32	22	40	•	2	VB...T 1604...
	QH40-SVUBR/L-16	40	32	27	50	•	2	

Spare parts

Designation	Screw	Shim	Shim screw	Wrench	
					
SVUBR/L-11	SO 25065I	-	-	T 7	
SVUBR/L-16	SO 35124I	SSV 32	SO 50090S	T 15	



QH-SWLNR/L

Screw type boring heads

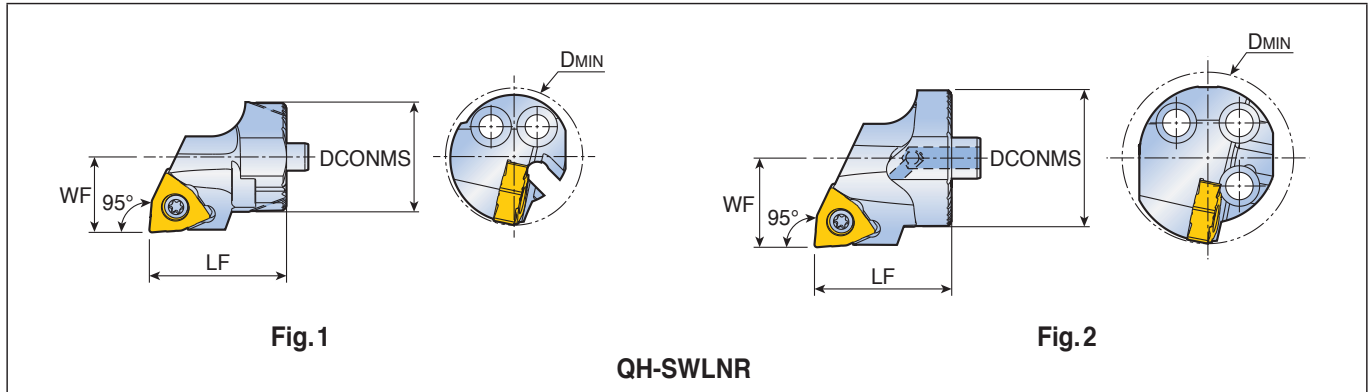

Approach angle	Designation	Dimension (mm)				Coolant	Fig.	Insert
		DCONMS	LF	WF	DMIN			
95°	* QH16-SWLNR/L-0403	16	20	11	20	●	1	WN...X 0403...
	* QH20-SWLNR/L-0403	20	20	13	25	●	2	

* Marked: For RHINO-M-TURN insert

Spare parts

Designation	Screw	Wrench			
SWLNR/L-0403	TS 25D060/HG-P	T 7P			

QH-SXUNR/L



Screw type boring heads

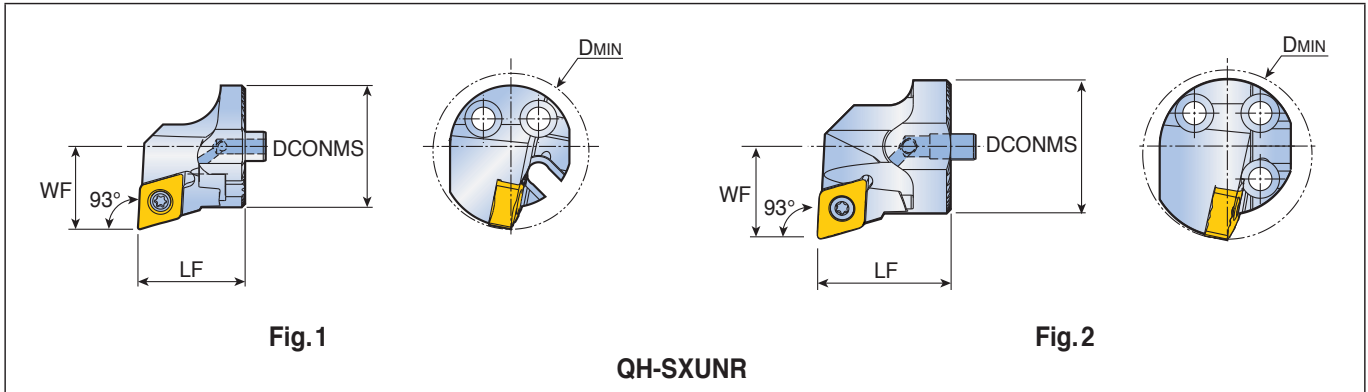

Approach angle	Designation	Dimension (mm)				Coolant	Fig.	Insert
		DCONMS	LF	WF	DMIN			
93°	◆ QH25-SXUNR/L-0904	25	22	17	32	•	1	XNMG 0904...
	◆ QH32-SXUNR/L-1105	32	32	22	40	•	2	XNMG 1105...

◆ Marked: For RHINO-X-TURN insert

Spare parts

Designation	Screw	Wrench			
	...0904	TS 30080I/HG	T 9		
...1105	TS 40G110I	T 15			